

TONGDA | 纺纱系统

转杯纺纱机
ROTOR SPINNING MACHINE



- 最长可达600锭，最高转杯设计速度11000RPM
- 模块化设计与丰富的可选配件，满足不同客户的需求
- 可配置创新型的落纱小车，使生产效率大幅提高
- 更多电子技术的应用，使设备更智能与高效



- Max spindles is up to 600 spindles, and the highest rotor design speed of 110000RPM.
- Modular design and abundant optional accessories to meet the needs of different customers.
- Innovative auto doffing device can be as option, which increase production efficiency greatly.
- More electronic technology applications make machine smarter and more efficient.

TONGDA | 纺纱系统

转杯纺纱机 ROTOR SPINNING MACHINE

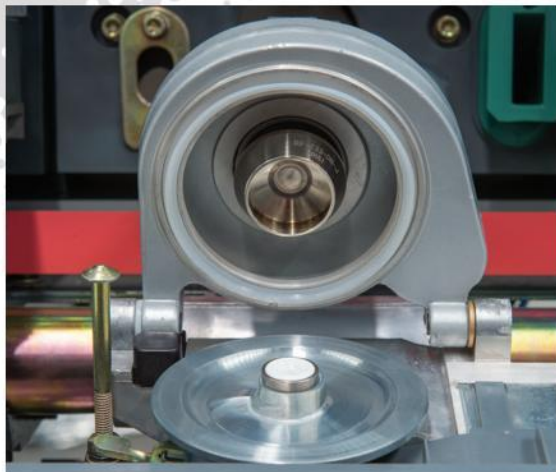

纺纱器-转杯纺的心脏

充分实验数据的采集与分析，对纺纱器通道进行优化，使适纺性与成纱质量达到完美结合。获得专利排杂系统，适应更广的原料，使客户从容面对市场变化，并减少工人劳动强度。通道口镶嵌高强度陶瓷，减少纤维对腔体的磨损，延长使用寿命。

Spinner- heart of the rotor spinning

It fully collects and analyzes the experimental data, optimizes the channel of spinner to realize a perfect combination between optimal spinning and yarn quality; With the patent trash-removal system and it can process more raw materials of different kinds, making the customers face the market changes at a leisurely pace and reducing the labor intensity of workers; The opening of channel is covered with ceramics of high strength, reducing the wear-and-tear of fiber to cavity and prolonging the service life;

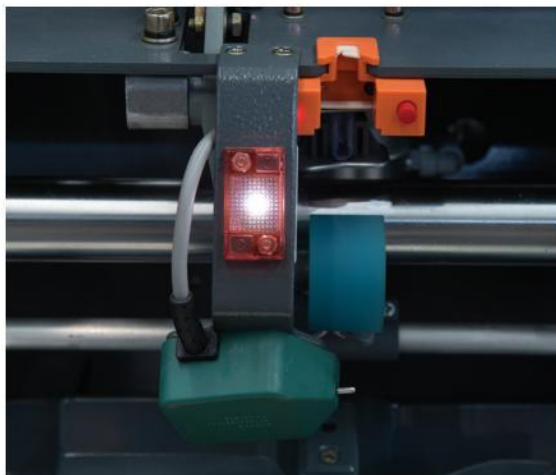

优易接头系统-高速纺纱的保证

标配气动抬升装置，断头响应时间仅为0.1秒；经过上百万次试验，可靠性高。独有的接头系统，接头时皮辊先于卷绕辊引纱，避免纱筒大小对于接头质量的影响。特有的接头数学模型与步进罗拉给棉，精确控制给棉量与给棉时间，保证接头强力与形态。

Optimal Joint System- The Promise Of High-Speed Spinning

The standard pneumatic lifting device whose breaking response is 0.1 sec only; millions of experiments have proved it has high reliability.

With the unique joint system, the roller is prior to the winding roller to guide the yarn when jointing to avoid the influence of bobbin to the quality of the joint. The exclusive mathematic jointing mode and stepping roller feeding accurately control the feeding volume and time to ensure the strength and shape of joint.



自动落纱小车-智能化的开端

开启半自动机器人模式，实现不断头自动落筒，降低劳动强度。高效性。从定位到落筒，完成一个标准落筒工作时间在20S以内。智能化，可以实现自动和手动模式落纱。

Automatic Doffing Device-Beginning Of Intelligent

beginning of intelligent, it starts the mode of semiautomatic machine to instead of labor work, to realize automatic doffing with no break ends, to reduce labor intensity. High efficiency, from fixed position to doffing, one standard doffing working time is within 20s. Intelligent, can realize automatic and manual mode of doffing.

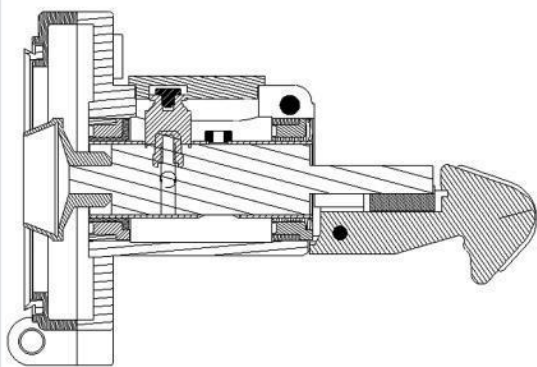

转杯轴承免拆装装置

该装置大大降低保全工的劳动强度，保证格距稳定性，提高了产品一致性。

Rotor bearing no need to disassembly

The device greatly reduces the labor intensity of the maintenance work, ensures the grid distance stability, and improves product consistency.

井纺织工业物联网云平台



健康互联网系统

客户主机程序可进行在线升级，可对客户主要传动部件进行在线监测与预警，客户可在全球各地实时了解自己设备的实际运行情况。

Health Internet System

Program of machine can be upgraded online, online monitoring and early warning of the main transmission components, and user can know the actual operation of equipment in real time around the world.



电子张力系统

采用数码控制，可以减少复杂的机械调节工作，客户可直接在车头显示屏上进行张力系数调节，调节精度可达0.001，保障了纱锭成型稳定。

Electronic Tension System

The digital control can reduce the complicated mechanical adjustment work. The user can directly adjust the tension coefficient in the monitor of headstock, and the adjustment precision can reach 0.001, which ensures the stable forming for winding package.

TONGDA | 纺纱系统

转杯纺纱机 ROTOR SPINNING MACHINE

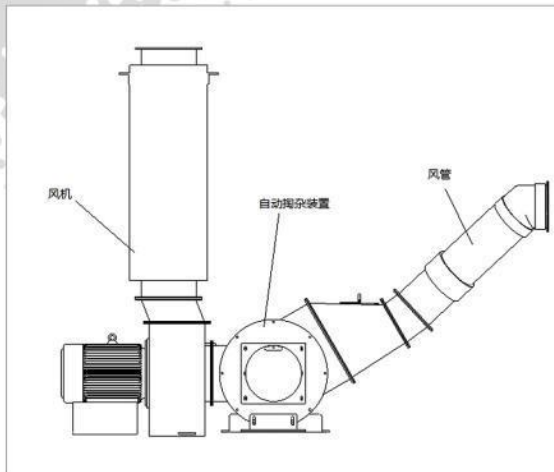

自动掏杂系统

该系统将减少挡车工的劳动强度，同时也为机台提供一个更加稳定的负压环境，使纱线的生产更加稳定，提高了纱线质量的一致性。

Automatic Take Out Impurity System

The system will reduce the labor intensity of the operator, and also provide a more stable negative pressure environment for the machine, which makes spinning production more stable and improves the consistency of the yarn quality.



正压散热系统

该系统可以减少飞花、粉尘在车头车尾内腔聚集，降低保全工的劳动强度，改善了电气元件的散热条件，从而增加了机台运行的稳定性，降低了能耗。

Positive Pressure Cooling System

The system can reduce the accumulation of flying and dust in the inner cavity of headstock and tail box, reduce the labor intensity of the maintenance worker, improve the heat cooling condition of the electrical components, thereby increasing the stability of the running of the machine and reducing the energy consumption.



全车色系改变

色系全部由意大利公司重新设计，色系相比现在将更加丰富与层次感，也会为客户带来全新的视觉冲击。

Color Change Of Whole Machine

The color of machine was completely redesigned by the Italian company. The colour will be plentiful and more layered than now, and it will bring new visual impact to user.

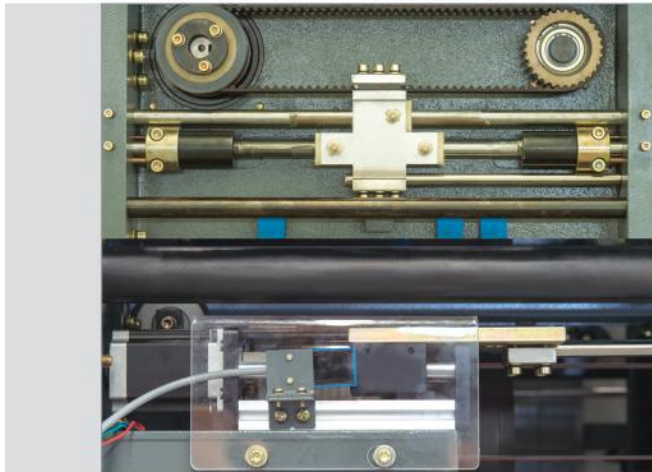

细节优化—所求完美

伺服驱动横动导纱，引纱速度达到200米/分。步进驱动微动机构，减少纱线对皮辊的磨损。优化的机架，减少操作高度，可配最高1100毫米的条筒。全机变频驱动，节能降耗；两侧独立传动，减少生产辅助时间。

Optimize The Details To Be Perfect

Servo drives transverse yarn guiding and the doffing speed can reach up to 200 m/min;The stepping micro-drive organs reduce the wear-and-tear of yarn to the roller;The optimized machine frame reduces the operating height and can be equipped with the car of 1200mm at most;The whole machine is driven with converse frequency, reserving the energy and reducing consumption;The two sides are transmitted independently which decreases the non-cutting time of production .

VAN DE WIELE
EXTRUSION

LGL

ABB

STÄUBLI

Schneider
Electric
施耐德电气

OMRON

SIEMENS

Panasonic

全球采购—品质保证

与知名供应商开展战略合作，专件全球采购，保证设备品质。完善的品管系统，确保产品质量。

Purchasing Worldwide To Ensure The Quality

We carry out strategic cooperation with well-known supplier, purchase a global sourcing to ensure the quality of equipment. Perfect and sound quality management system ensures the quality of the products.

技术规格和尺寸图 SPECIFICATION & DIMENSIONS

项 目	单 位	技术指标
转杯转速	r/min	45000-110000双面独立传动, 变频调节
引纱速度	m/min	最高200
导纱角	度	30°-42°无级调节
分梳辊转速	r/min	6000-11000双面独立传动, 变频调节
抽气风机排气量	m³/h	≤9000, 变频器调节
适纺纱线密度	tex(Ne)	120-15 (5-40)
适纺纤维长度	mm	≤60mm
牵伸倍数	倍	20-280
捻度范围	t/m	200-2000
喂入条子	ktex	2.5-7
张力牵伸倍数	倍	0.6-1.5
分梳辊直径	mm	65
转杯直径	mm	33/34/36/40/50/54
锭距	mm	230
总锭数	锭	≤600
1节中段的锭数	锭	20
平筒纱管规格 (内径×长度)	mm	Φ42 (卷边) / 54 (直边) Φ42 (卷边) / 50 (直边)
锥筒纱管规格 (内径×长度)	mm	2°Φ44 (卷边) / 65 (直边)
条筒规格 (外径/高度)	mm	16" (Φ400)、18" (Φ450)、20" (Φ530) / 标准高度900, 可选1100
卷装规格 (直径)	mm	平筒 最大Φ300 锥筒 最大Φ270
满筒纱的重量	kg	最大4
抬臂装置		气动自动抬升
机器长度	m	≤77.8
机器重量	kg	头+N节中段+尾 (N≤30) 3500+800*N+3100
最大装机容量	kw	195

地脚图 (520锭以下)

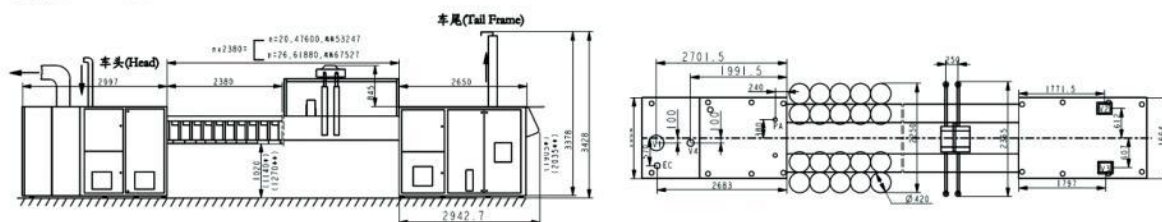

Item	Unit	Technical index
Rotational Speed of Revolving Cup	r/min	45000-110000 independent drive from two way , and with frequency conversion adjustment ;
Doffing Speed	m/min	With maximum of 200
Doffing Angle	Degree	30°-42°step-less regulation
Rotational Speed of Opening Roller	r/min	6000-11000 independent drive from two way , and with frequency conversion adjustment ;
Air capacity of Air Exhaust Fan	m³/h	≤9000, regulated by frequency transformer
Density of Optimal Yarn	tex(Ne)	120-15 (5-40)
Length of Optimal Fiber	mm	≤60mm
Draft Ratio	Times	20-280
Scope of Twist	t/m	200-2000
Feeding Bar	ktex	2.5-7
Draft Ratio of Tension	Times	0.6-1.5
Diameter of Opening Roller	mm	65
Diameter of Revolving Cup	mm	33/34/36/40/50/54
Spindle Distance	mm	230
Total Spindle	Spindle	≤600
The Number of spindles of middle stage in first section	Spindle	20
Specification of Flat Bobbin (Inner Diameter × Length)	mm	Φ42 (Rolling edge) /54 (Straight edge) Φ42 (Rolling edge) /50 (Straight edge)
Specification of Taper Bobbin (Inner Diameter × Length)	mm	2°Φ44 (Rolling edge) /65 (Straight edge)
Specification of Can (Outer Diameter / Height)	mm	16" (Φ400) 、 18" (Φ450) 、 20" (Φ530) /standard height 900, 1100 is optimal
Specification of Rolling (Diameter)	mm	As to flat bobbin, Φ300 is at maximum; As to taper bobbin, Φ270 is at maximum.
Weight of A Full Bobbin	kg	With maximum of 4
Lifting Device		Automatic air drive lifting
Length of Device	m	≤77.8
Weight of Device	kg	Head+ the middle part in N section+ Tail (N≤30) 3500+800*N+3100
Maximum Loading Volume	kw	195

Installation drawing (540锭以上, 车头长度增加了666mm)

